



IndiTech Valves Pvt. Ltd.



First Indian Manufacturer of
Tilting Disc Type QCNRV



Self-acting and quick closing
in less than 0.3 seconds!!!

Quick Closing
NRV

Series 350

Series

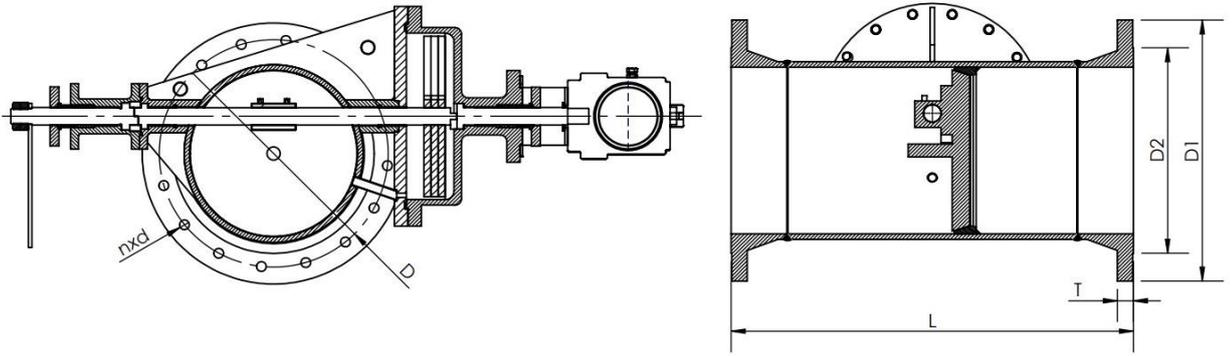

CLASS 150								
DN	NPS	D	D1	D2	T	L	d	n
100	4	190.5	229	157.2	23.9	292	19	8
150	6	241.3	279	215.9	25.4	356	22	8
200	8	298.4	343	269.9	28.4	495	22	8
250	10	362	406	323.8	29.9	622	25	12
300	12	431.8	483	381	31.7	698	25	12
350	14	476.2	533	412.8	34.8	787	28.5	12
400	16	539.8	597	469.9	36.6	914	28.5	16
450	18	577.8	635	533.4	39.6	978	32	16
500	20	635	693	584.2	42.6	978	32	20
550	22	692.2	749	641.4	45.9	1067	35	20
600	24	749.3	813	692.2	47.5	1295	35	20
CLASS 300								
DN	NPS	D	D1	D2	T	L	d	n
100	4	200.2	254	157.2	31.7	356	22	8
150	6	269.7	318	215.9	36.6	444	22	12
200	8	330.2	381	269.9	41.1	533	25	12
250	10	387.4	444	323.8	47.5	622	28.5	16
300	12	450.8	521	381	50.8	711	32	16
350	14	514.4	584	412.8	53.8	838	32	20
400	16	571.5	648	469.9	57.1	864	35	20
450	18	628.6	711	533.4	60.2	978	35	24
500	20	685.8	775	584.2	63.5	1016	35	24
550	22	743	838	641.4	66.5	1118	41	24
600	24	812.8	914	692.2	69.8	1346	41	24

Quick Closing NRV

Series 350

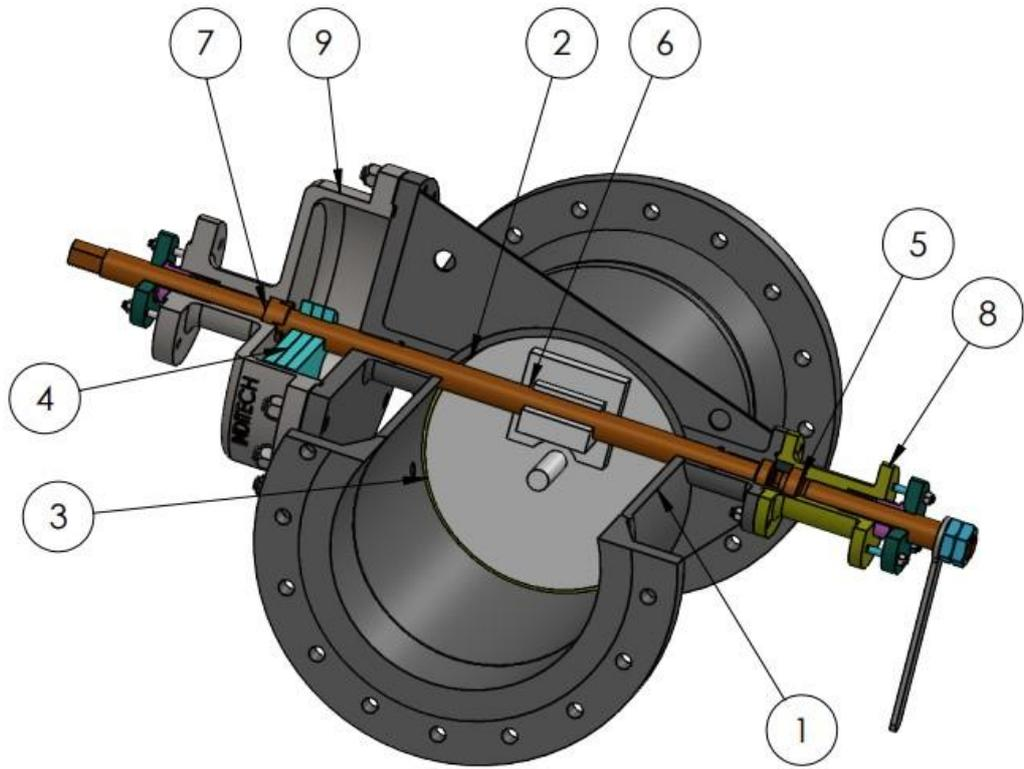
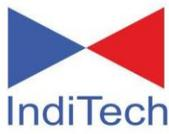

Sl. No	DESCRIPTION	MATERIAL	HARD FACING MATERIAL	
			TEMP UPTO 350 °C	TEMP ABOVE 350 °C
1	BODY	*CARBON STEEL / ALLOY STEEL	--	--
2	SEAT	CARBON STEEL	A479 SS410	STELLITE 6
3	DISC	CARBON STEEL	A479 SS410	STELLITE 6
4	COUNTER WEIGHT	CARBON STEEL	--	--
5, 6, 7	STEM	A479 SS410	--	--
8	STUFFING BOX	*CARBON STEEL / ALLOY STEEL	--	--
9	COUNTER WEIGHT HOUSING	*CARBON STEEL / ALLOY STEEL	--	--

*OTHER MATERIALS AVAILABLE UPON REQUEST

Quick Closing NRV

Series 350

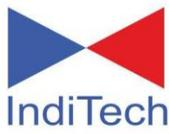

ACTUATOR TO CLOSE THE VALVE IN EMERGENCY IN LESS THAN 0.3 SEC

COUNTER WEIGHT FOR BALANCING DISC

TILTING TYPE DISC

CLOSED CHAMBER FOR COUNTER WEIGHT

LEVER TO CHECK HEALTHY OPERATION OF DISC DURING NORMAL OPERATION

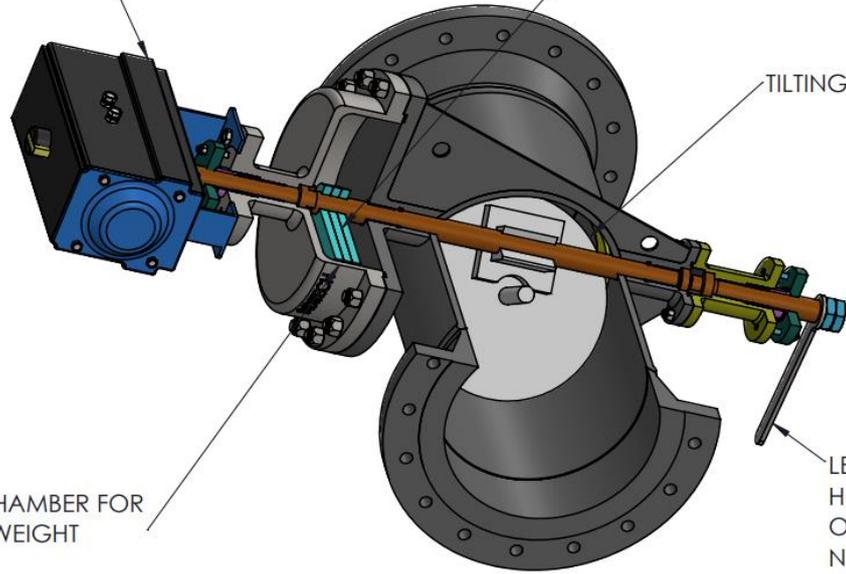

DN	NPS	CLASS		
		150	300	600
100	4	●	●	●
150	6	●	●	
200	8	●	●	
250	10	●	●	
300	12	●	●	
350	14	●	●	
400	16	●	●	
450	18	●	●	
500	20	●	●	
550	22	●	●	
600	24	●	●	

Technical Data

Parameters	Standard Values
Size	NPS 4 TO NPS 24
Pressure Rating	ANSI CL150 / CL300 / CL600
Service Media	Steam / Water / Gas
End Connections	Flanged as per ASME B16.5 / Butt Weld as per ASME B16.25
Body Material	Carbon Steel / Alloy Steel / Others on request
Actuator	Pneumatic / Hydraulic

Features

- Self-acting and quick closing with pneumatic actuator in less than 0.3 secs
- Equipped with counterweight for balancing of disc and lever to check disc movement
- Suitable to install on vertical and horizontal pipelines
- Minimisation of water hammer
- Low pressure loss
- Chatter free operation and suitable for pulsating flows
- Maintenance free, long service life
- Guaranteed drop tight leak tightness
- Light weight construction compared to bulky swing type QCNRV

Applications

- Widely used in Power Plants
- Boiler Feed Water Line
- Main Steam Extraction lines
- Cold Reheat Line
- For preventing backflow in feed water heaters, auxiliary turbines and other equipment

Contact Us

Regd. Office:

21 'Shubham', Prosperity Society,
Karvenagar, Pune - 411052, India.
Tel: +91 20 25420021
Email: info@inditechvalves.com

Works:

Plot No. 5, Gat No. 171, 172 & 177,
Village Dhanore, Alandi Markal Road,
Pune - 412105, India.

www.inditechvalves.com

IndiTech Reserves the right to modify product design and specification without prior notice.

Industry proven performance
since 22+ years